

15BRP-9

3,000 lbs capacities · Electric Double Deep Reach Truck

18/20/23BRP-9

3,500 / 4,000 / 4,500 lbs capacities · Electric Single Deep Reach Truck

HYUNDAI

MATERIAL HANDLING

NO ONE DELIVERS MORE

MORE PERFORMANCE.
MORE FEATURES.
TO LET YOU DO MORE
IN TIGHT SPACES.



Get more, do more, save more with THE BRP-9 FROM HYUNDAI

With its tight turning radius and compact design, the BRP-9 reach trucks are engineered to deliver greater efficiency, outstanding maneuverability, and superior dependability in narrow aisle operations. With its advanced features, the BRP-9 brings more uptime with simplified maintenance, enhanced productivity, and unmatched operator comfort to virtually any warehouse application.

From pick to pick, up and down narrow aisles, shift after shift, day after day, the BRP-9 Series can help you generate greater profits, as you move more pallets, more quickly, and more cost effectively than ever before.



GREATER VISIBILITY ALL AROUND

The BRP-9 was designed to give your operators maximum visibility. The mast features an optimized cylinder arrangement for greater forward visibility with a clear view of the forks. An optional color LCD monitor and camera are available. The camera can be mounted either at the top or the bottom of the carriage. This provides enhanced visibility when interfacing with higher beam levels, or when interfacing with the second pallet in double deep rack systems.



100% AC ZAPI CONTROL SYSTEM

The advanced ZAPI control system combines greater power with extended service intervals to drive up productivity and cut downtime. The system provides smooth, quiet operation and protection from overheating. Adding to the reliability of the system, the AC motors are equipped with temperature sensors to ensure long motor life, maximum reliability, and efficiency all with low noise levels while working.



OPTIONAL LITHIUM-ION BATTERY

The BRP-9 Series can deliver even greater uptime with an optional Li-ion battery. Li-ion batteries feature rapid charging in just 2 hours and deliver outstanding performance, ideal for daily two-shift work without the need to replace the battery. Compared to traditional lead batteries, a Li-ion battery delivers 10% greater efficiency—for reduced energy and infrastructure costs while delivering greater productivity.



MULTIFUNCTION DIGITAL CLUSTER OPTIMIZES EQUIPMENT PERFORMANCE

Our LCD cluster consolidates important equipment information, real-time data, onboard diagnostics, data logging, safety features, and maintenance tracking while providing safety and maintenance alerts to keep operators informed on equipment status. Navigable menus, settable performance parameters, and incorporated safety features increase operator proficiency, safety, and throughput.



CONTROLS THAT MINIMIZE OPERATOR EFFORT AND MAXIMIZE HANDLING

Ergonomics are front and center in the BRP-9. The steering control, coupled with electric power steering, provides exceptionally smooth and precise handling in tight spaces. The conveniently positioned control handle allows operators to raise and lower the forks and control the travel function and horn with just one hand. The handle's contoured design and cushioned armrest add even greater operator comfort.

The BRP-9 Series brings you even more advantages.

- Excellent gradeability from 13% to 18% with fast travel speeds up to 7.3 MPH assure greater productivity in even challenging working environments
- Anti-rollback prevents unintended movement while operating on a grade—incline or decline—increasing safety in the workplace
- Curve control reduces the risk of the operator exceeding the safe speed of the forklift when negotiating a turn by controlling the travel speed and acceleration of the unit
- Load weight indicator provides the operator with an audible and visual alarm should the operator try to exceed the rated load capacity of the forklift
- Strong overhead guard exceeds CEE and ANSI regulations offering greater protection and excellent overhead visibility
- Optional camera, with LCD monitor, can be installed on the fork side to give operators a clear view when picking or placing loads
- State-of-the-art, large capacity hydraulic system responds quickly and features a low-noise valve that increases both efficiency and durability
- Operator comfort is enhanced with a heavy, vibration dampening, non-slip floor mat and an adjustable, cushioned backrest that together reduce operator fatigue

HiMATE



ONLY HYUNDAI OFFERS YOU SUCH A COMPREHENSIVE, FULLY INTEGRATED TELEMATICS SYSTEM.

Hi-Mate works by collecting key data from sensors mounted to your equipment that track operation of the forklift, relaying that information to your computer or mobile device in real time. By monitoring key components, such as the engine, electric system, and hydraulics, Hi-Mate can help you evaluate machine and operator performance, create preventive maintenance programs, and help you minimize downtime as you maximize productivity.

Equipment operation management

Real-time monitoring and follow-up management of individual pieces of equipment or equipment fleet deliver essential operational status and information, including:

- Key-on time, travel hours, work hours, and GPS location

Equipment status management

Vital diagnostic and maintenance data is relayed as alerts, while Hi-Mate Premium provides tracking of pre-shift checklists to help reduce downtime and ensure OSHA compliance:

- Alerts are sent for DTCs, system warning, and required maintenance

Safe traveling control

An impact monitor provides alerts, accountability, and follow-up management of safety incidents involving equipment during operation:

- The system logs the number and severity of impacts as well as the operator who was logged into the unit at the time of the incident

Human resource management

Hi-Mate Premium can control who operates equipment via a pin pad and RFID reader:

- Provided information can be used to evaluate productivity, efficiency, and workforce safety
- Tracking the weight load indicator captures operator productivity

HI-MATE MANAGEMENT SYSTEM

Hi-Mate is one of the industry's most advanced remote management system. With continuous data collection, Hi-Mate delivers more communication, control, and ability to track, monitor, maintain, and manage your forklift fleet. It is the proven way to efficiently coordinate both your equipment and human resources.

Data Flow

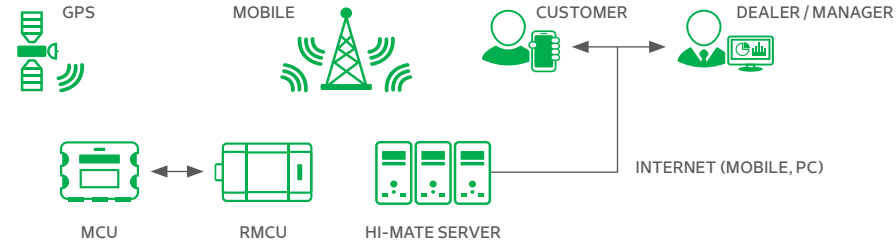

Dimensions

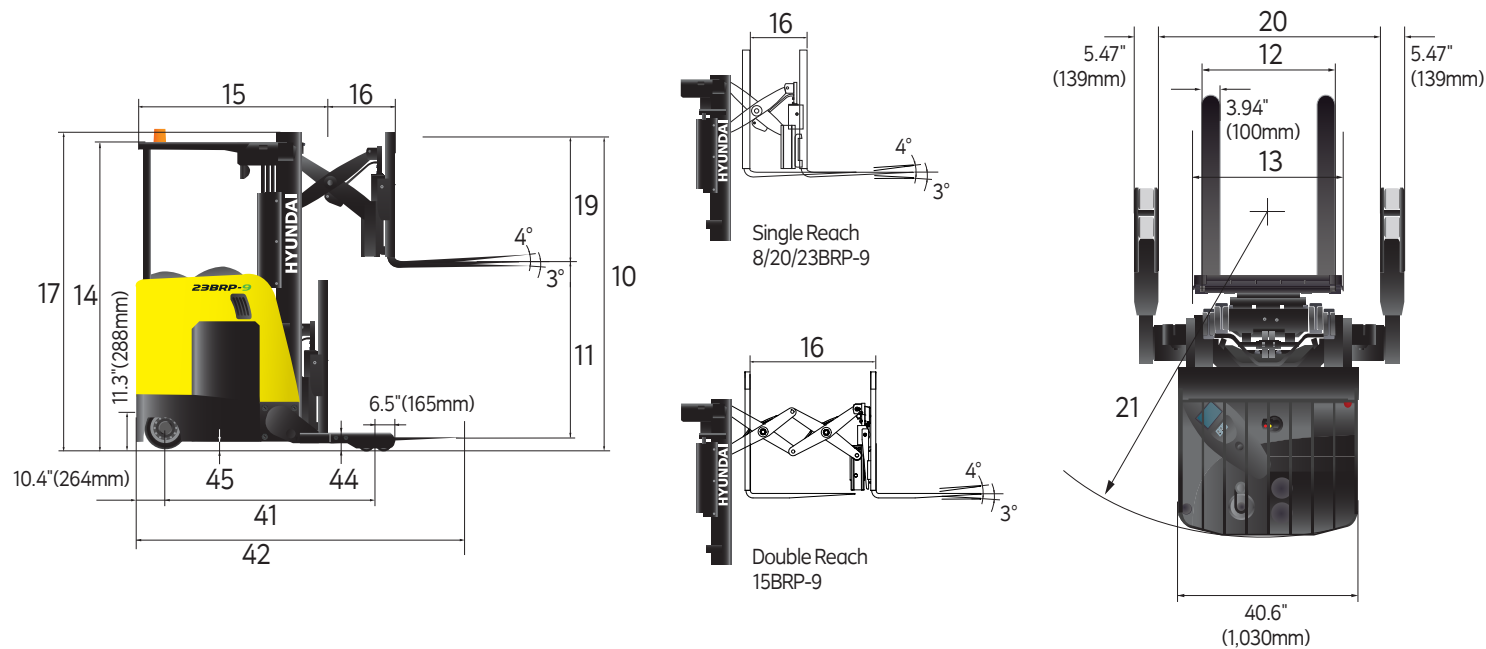

Specifications

Specifications							
Identification							
1	Manufacturer			Hyundai			
2	Model	Manufacturer's Designation		15BRP-9	18BRP-9	20BRP-9	23BRP-9
3	Load Capacity * 1	Max	lbs	3,000	3,500	4,000	4,500
4	Load Center	Fork Face to Load CG	in	24	24	24	24
5	Power Unit	Type	Volt	36	36	36	36
6	Operator Type	Stand, Double / Single Reach		Stand / Double Reach	Stand / Single Reach		
7	Tire Type	Load/Drive / Caster		PE			
8	Wheels (x=driven)	Number, Load / Drive / Caster		4 / 1x / 2	4 / 1x / 2	4 / 1x / 2	4 / 1x / 2
Basic Dimensions							
10	Lift Height	See Chart	in	210	210	210	210
11	Free Lift	See Chart	in	47	47	47	47
12	Overall Fork Width	Min. ~ Max.	in	13~30	13~30	13~30	13~30
	Fork Dimensions	H x W x L	in	1.57 x 3.9 x 41.3		1.77 x 3.9 x 41.3	
13	Carriage Width	in standard	in	33.7	33.7	33.7	33.7
14	Overhead Guard Height	Length	in	94.5	94.5	94.5	94.5
15	Length to Fork Face* (3)	Battery Compartment * Type A*	in	59.2	51.9	N/A	N/A
		Battery Compartment * Type B*	in	61.2	53.9	53.9	53.9
		Battery Compartment * Type C*	in	63.0*(4)	N/A	55.6	55.6*(4)
		Battery Compartment * Type D*	in	65.7	N/A	N/A	58.4
16	Reach (Pantograph)	Stroke	in	42.8	23.3	23.3	23.3
17	Overall Height* (2)	Lowered, See Chart	In	95.1	95.1	95.1	95.1
		Lifted, See Chart	in	258	258	258	258
19	Load Backrest Height		in	48	48	48	48
20	Outrigger ID	in 2" increments(34"~50"	in	42	42	42	42
21	Turning Radius	Battery Compartment * Type A*	in	70.8	66.5*(4)	N/A	N/A
		Battery Compartment * Type B*	in	72.8	68.5	68.5*(4)	71.3
		Battery Compartment * Type C*	in	74.5*(4)	N/A	70.2	73.0*(4)
		Battery Compartment * Type D*	in	77.2	N/A	N/A	75.7
22	Battery Compartment	Length	in	18.0	14.3	16.3	18.0
Performance							
24	Travel Speed	loaded / unloaded	mph	7.3 / 7.3		7.3 / 7.3	
26	Lift Speed	loaded / unloaded	fpm	63 / 89	61 / 89	57 / 57	53 / 57
28	Lowering Speed	loaded / unloaded	fpm	98 / 89		98 / 89	
Weights							
34	Service weight	Including battery, standard	lbs	8,781	7,408	7,727	8,600
35	Axle loading	loaded front	lbs	7,143	7,031	7,762	8,576
		loaded rear	lbs	4,639	3,878	3,964	4,524
		unloaded front	lbs	3,512	2,879	3,045	3,406
		unloaded rear	lbs	5,269	4,528	4,683	5,194
Chassis							
40	Wheel Size	Front, Load Wheels	In	ø5 x 4		ø5 x 4	
		Rear, Drive Wheel(Steer)	in	ø13.5 x 5.5		ø13.5 x 5.5	
		Rear, Caster Wheel	in	ø7 x 2.87		ø7 x 2.87	
41	Wheelbase	Battery Compartment * Type A*	in	59.4	55.1*(4)	N/A	N/A
		Battery Compartment * Type B	in	61.5	57.1	57.1*(4)	59.9
		Battery Compartment * Type C*	in	63.2*(4)	N/A	58.8	64.4*(4)
		Battery Compartment * Type D*	In	65.9	N/A	N/A	64.4
42	Overall Length	in standard battery compartment	in	104.3	93.2	95.2	97.0
44	Ground Clearance	With 5" diameter load wheels	in	2.0	2.0	2.0	2.0
45	Battery Roller Height	With 5" diameter load wheels	in	6.5	6.5	6.5	6.5
46	Service Brake	Type		Electric Disc Brake			
47	Parking Brake	Type		Automatic Electric release			
	Steering	Type		Electric Steering			
Motor & Battery							
48	Battery	Type	mph	Lead Acid			
		Max. Amp -standard		1,085	775	930	1,085
		Min. Weight -standard	lbs	2,261	1,633	1,884	2,261
49	Motors, Controls	Drive Motor, 60 Min Rating	kw	6.8	6.8	6.8	6.8
		Hydraulic Motor, 15% Rating	kw	16.0	16.0	16.0	16.0
		Drive & Hydraulic Motor control Type		AC	AC	AC	AC

15/23BRP-9

Mast Type	Maximum Fork Height	Overall Height (Lowered)	Overall Height with Backrest (Lifted)	Free Lift Height with Backrest	Over Headguard Height	Minimum Outrigger I.D.	Truck Weight - w/o Battery								
							"A" Type B.C. 14.5"		"B" Type B.C. 16.5"		"C" Type B.C. 18.3"		"D" Type B.C. 21.1"		
							15/23BRP-9	15/23BRP-9	15/23BRP-9	15/23BRP-9	15/23BRP-9	15/23BRP-9	15/23BRP-9	15/23BRP-9	15/23BRP-9
	in	in	in	in	in	in	lbs	lbs	lbs	lbs	lbs	lbs	lbs	lbs	
3-Stage Full Free Lift	TF500	197.3	89	245.3	41	88.2	34	6327.3	-	6367	6184	6398	6217	6448.5	6267.7
	*TF530	210	95	258	47	94.3	34	6433	-	6470.6	6288	6501.4	6320.7	6552.1	6371.4
	TF610	240	107	288	59	94.3	34	6783.6	-	6823.3	6640.3	6854.2	6673.4	6904.9	6724
	TF685	270	119	318	71.1	94.3	34	-	-	7024	6843.1	7057	6876.2	7107.7	6926.9
	TF760	300	131	348	83	94.3	34	-	-	7247	7046	7260	7076.8	7310.5	7127.5
	TF815	321	140	369	92	94.3	34	-	-	7385.5	7202.5	7416.4	7235.6	7467	7286.3
	TF865	341	149	389	101	94.3	40	-	-	-	-	-	-	7828.6	7647.8
	TF930	366	160	414.2	112	94.3	42	-	-	-	-	-	-	7828.6	7647.8
TF1010	400	172	448	124	94.3	44	-	-	-	-	-	-	8073.3	7892.6	

* Standard

18/20BRP-9

Mast Type	Maximum Fork Height		Overall Height (Lowered)		Overall Height with Backrest (Lifted)		Free Lift Height with Backrest		Over Headguard Height		Minimum Outrigger I.D.		Truck Weight - w/o Battery						
	18BRP-9	20BRP-9	18BRP-9	20BRP-9	18BRP-9	20BRP-9	18BRP-9	20BRP-9	18BRP-9	20BRP-9	18BRP-9	20BRP-9	"A" Type B.C. 14.5"		"B" Type B.C. 16.5"		"C" Type B.C. 18.3"		
	in	in	in	in	in	in	in	in	in	in	in	in	in	in	lbs	lbs	lbs	lbs	lbs
3-Stage Full Free Lift	*TF500	197.3	197.3	89	89	245.3	245.3	41	41	88.2	88.2	34	34	5725.4	-	5765.1	5765.1	-	5796
	TF530	210	210	95	95	258	258	47	47	94.3	94.3	34	34	5809.2	-	5848.9	5848.9	-	5879.7
	TF610	240	240	107	107	288	288	59	59	94.3	94.3	34	34	6120	-	6157.5	6157.5	-	6188.4
	TF685	270	270	119	119	318	318	71.1	71.1	94.3	94.3	34	34	-	-	6353.7	6353.7	-	6384.6
	TF760	-	300	-	131	-	348	-	83	-	94.3	-	34	-	-	-	-	-	-
TF815	-	321	-	140	-	369	-	92	-	94.3	-	34	-	-	-	-	-	-	6673.4

* Standard

Battery Table

Battery Type	Battery Compartment Size (Length)	Battery Voltage	Maximum Capacity (6 Hour Rate)	Battery Dimensions			Battery Weight
				Width (W)	Length (L)	Height (H)	
	in	Volt	Ah	in	in	in	lbs
Type A	14.3	36	775	38.4	14.0	31	1,598
Type B	16.3	36	930	38.4	16	31	1,878
Type C	18.0	36	1,085	38.4	17.7	31	2,280
Type D	20.7	36	1,240	38.4	20.5	31	2,601

Load Tire Option Table

Mast Type	15BRP-9		18BRP-9		20BRP-9		23BRP-9	
	ø5x4"	ø10.5x4"	ø5x4"	ø10.5x4"	ø5x4"	ø10.5x4"	ø5x4"	ø10.5x4"
TF500	●	-	●	●	●	●	●	●
TF530	●	-	●	●	●	●	●	●
TF610	●	-	●	●	●	●	●	●
TF685	●	-	●	●	●	●	●	●
TF760	●	-	-	-	●	-	●	●
TF815	●	-	-	-	●	-	●	●
TF865	●	-	-	-	-	-	●	-
TF930	●	-	-	-	-	-	●	-
TF1010	●	-	-	-	-	-	●	-

Load Capacity

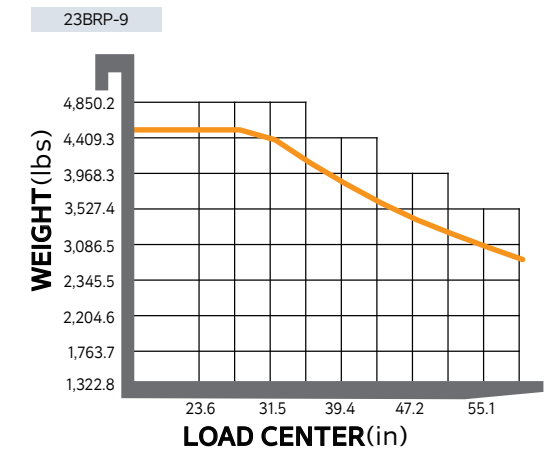
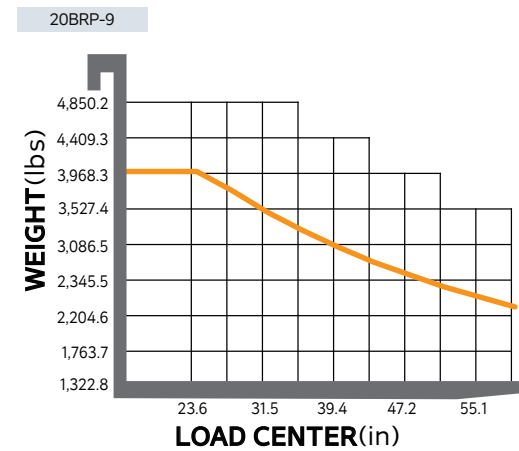
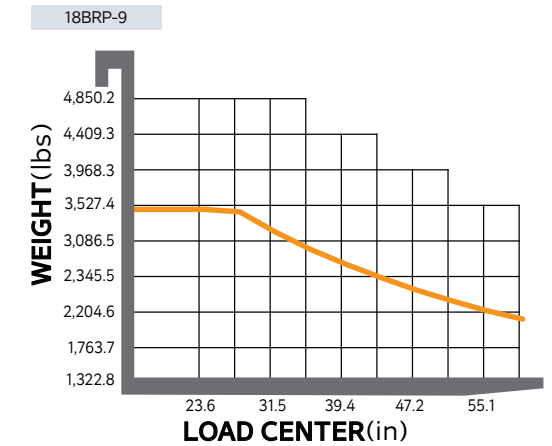
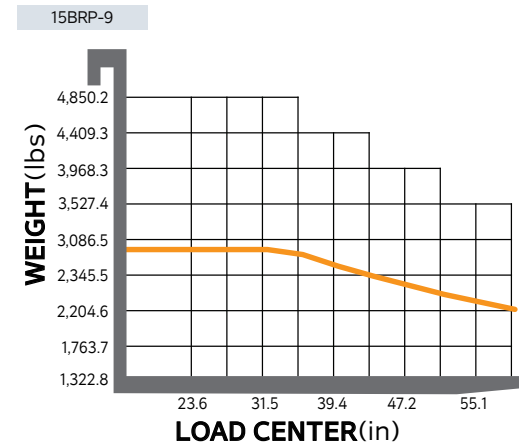

Model	Mast	Battery Type	Outrigger-I.D.
15BRP-9	TF530	C	42 in
18BRP-9	TF530	A	42 in
20BRP-9	TF530	B	42 in
23BRP-9	TF530	C	42 in

Right Angle Aisle Stacking - Zero Clearance

14.25" Battery Compartment and 42" Outrigger I.D.					14.25" Battery Compartment and 42" Outrigger I.D.					16.25" Battery Compartment and 42" Outrigger I.D.										
15BRP-9					18/20BRP-9					23BRP-9										
Pallet Length (in)	Pallet Width (in)					Pallet Length (in)	Pallet Width (in)					Pallet Length (in)	Pallet Width (in)							
		33	36	40	44		48		33	36	40		44	48		33	36	40	44	48
	36	92	91.6	91.2	90.8		90.5	36	84.1	83.8	83.4		82.9	82.4	36	87.3	86.9	86.5	86.5	85.5
	40	96.3	96.1	95.8	96.7		95.2	40	88.8	88.5	88.2		87.8	87.4	40	92	91.7	91.4	91.4	90.6
	44	100.7	100.5	100.2	100		99.7	44	93.2	93	92.7		92.4	92.1	44	96.5	96.3	96	96	95.4
48	104.9	104.8	104.5	104.3	104	48	97.5	97.3	97.1	96.9	96.6	48	100.8	100.6	100.4	100.4	99.8			

* Add 6 in. to 12 in. for ease of maneuverability.

· Add 2 in. for 16.3 in. Battery Compartment
· Add 3.5 in. for 18 in. Battery Compartment
· Add 6 in. for 20.7 in. Battery Compartment

· Add 2 in. for 16.3 in. Battery Compartment
· Add 3.5 in. for 18 in. Battery Compartment

· Add 2 in. for 18 in. Battery Compartment
· Add 4 in. for 20.7 in. Battery Compartment

Options

Carriage

- Integral Sideshift - Max 4.7 in

Outrigger I.D. (in)

- 34
- 36
- 38
- 40
- 44
- 46
- 48
- 50

Fork Length (in)

15/18BRP

- 35.4 (std)
- 37.4
- 39.4
- 41.3
- 45.3
- 47.2
- 53.2
- 59.1
- 63

20/23BRP

- 35.4 (std)
- 39.4
- 47.2
- 53.2
- 59.1
- 65
- 70.9

Fence

- Wire Net Type

Tire

- Vulkollan®

Li-Ion Battery and Matching Chargers

Battery Compartments

- 14.2", 16.3", 18.0", and 20.7" available on select models

Height Indicator

Cold Storage Conditioning

UL

- EE Rating

Beacon Lamp

- Amber

Rear Work Lamp

Rear Blue Light

Red Zone Light

Camera

Safety Speed Lock

**NO ONE
DELIVERS MORE**



6100 Atlantic Blvd.
Norcross, GA 30071
hyundaiforkliftamericas.com

678-823-7777