

# 33PPWN / 45PPWN Powered Pallet Walkie Narrow

## 3,300 / 4,500 LBS Capacity

- Brushless DC drive motor
- 24V 33PPWN Curtis control system
- 48V 45PPWN Curtis control system
- Great gradeability performance
- Low consumption of energy



## Powered Pallet Walkie Narrow



# **HYUNDAI** **MATERIAL HANDLING**

The Hyundai electric pallet truck is the innovative product with cutting-edge design based on decades of experience! It combines the advantages of manual and electric pallet trucks being the perfect electrical product for light and medium duty material handling in most effortless and economic way.



**Smart Design**

**Robust**

**Safety**

**Ergonomics**

**High Performance**

**Maintenance Friendly**

# Ergonomic & Smart Tiller Design

The tiller of the truck with ergonomic design has soft grips for comfortable daily operation. All buttons are big and can be easily reached by operators even while wearing gloves.

Integrated PIN code panel with LCD display for smart control and operation.

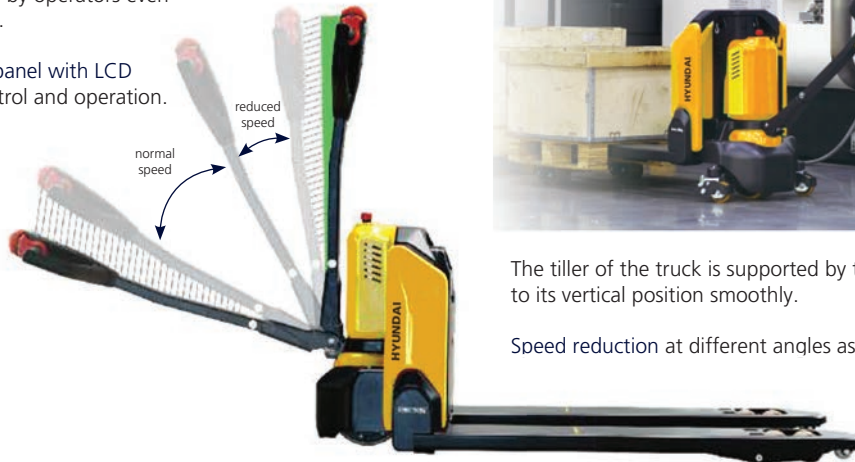

The tiller of the truck is supported by the air spring and the tiller returns to its vertical position smoothly.

Speed reduction at different angles as well as function of active tiller in



The EDGE can be operated with the tiller in the vertical position, allowing the operator to work in confined areas such as elevators, trailers and narrow aisles.



# Robust & Smart Design of Chassis

Strong and compact structure of chassis helps to ensure long life-time of the truck, without sacrificing the truck's weight or putting under question the strength of frame.

The frame of truck is surrounded by stamped steel elements making the truck looking different and also ensuring the protection of components.



Strong steel apron protects the operator's feet during work and secures the truck's components from collisions with objects.



Forks of the truck with shape for easy entrance and exit from pallets. Full length double sided C-shape reinforcements of forks significantly increase strength and rigidity of frame.

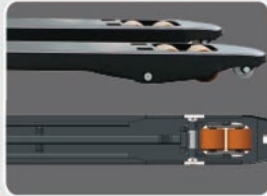

Standard with suspension stability casters for great stability for applications of all kinds.



Capacity up to **3,300 lbs** and ability to overcome ramps up to **4/16%** (loaded/unloaded) makes the truck suitable for work in loading docks and on delivery operations.

Capacity up to **4,500 lbs** and ability to overcome ramps up to **7/16%** (loaded/unloaded). Standard with German INTORQ brake for safety.



# EDGE



**27 in Fork: 337 lbs**  
**685 mm Fork: 153 kg**

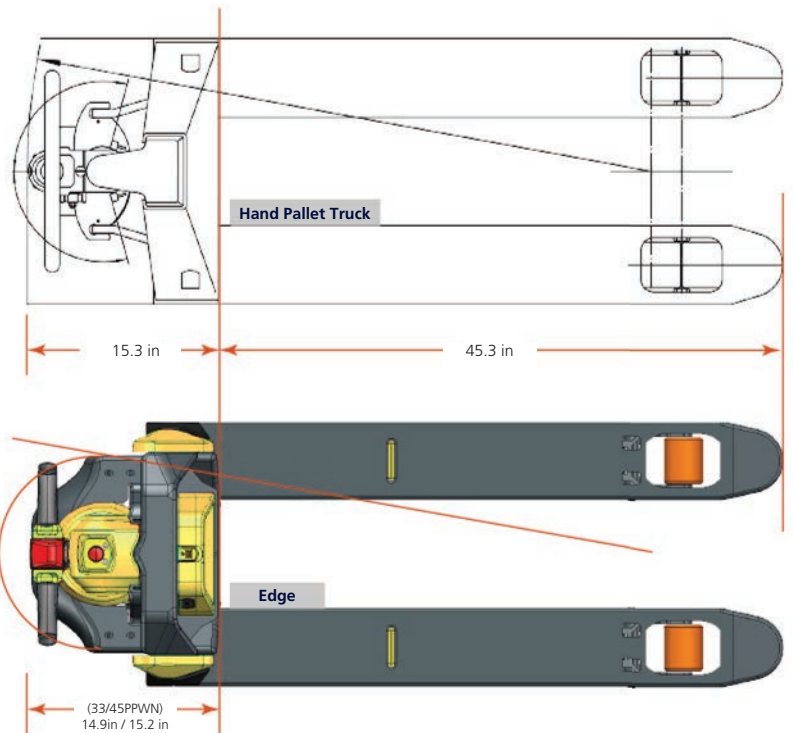

The short body length of truck (L2 = 33PPWN 14.9 in / 45PPWN 15.2 in) is even smaller than a conventional hand pallet jack. It provides the shortest turning radius of (33) 50/52.3 in and (45) 50.4/52.6 in with lifted/lowered forks and makes the truck extremely compact and ideal for use in confined spaces of retail stores, elevators or business centers.

# Smart Lithium Battery

Standard with Maintenance-free 48V/20Ah Lithium battery and 48V/9A intelligent charger for long operation time, fast charging and opportunity charging.

The integrated **BMS** (Battery Management System) controls all important parameters and performance of lithium battery.



Smart battery positioning and lock for great fixation and safety.



Light weight high quality Lithium battery for **easy replacement**.



Socket on battery case for easy battery charging without necessity to take the battery out

Fast and opportunity charging during breaks in operations increases working time.



min 2.5 hours charge



3 - 6 hours working time



Standard stability castors

# Maintenance Friendly

48V Brushless DC drive motor with intelligent Curtis control



**Convenient** and fast access to any component of the truck, no elements are located in areas difficult to reach. No special tools are required.

There are no hoses or pipes used in the hydraulic lifting circuit which significantly improves **reliability** and reduces the amount of potential problems related to leakages through connectors or their seals.



Please write single or tandem rollers

## Optional LBR Heights

- 42 in - 45PPWN
- 48 in - 33 / 45PPWN
- 60 in - 45PPWN



Optional Backrest



The truck is equipped with **Curtis** controller and **CAN-Bus** technology makes the diagnostic and troubleshooting easier.

Amount of working hours shown at the tiller helps to follow the maintenance schedule.



Optional different fork sizes

**AUTHORIZED DEALER**

**Hyundai Material Handling**

6100 Atlantic Blvd.  
Norcross, GA 30071  
P: 678-823-7777  
TF: 1-877-509-2254  
F: 678-823-7778  
hyundaiforkliftamericas.com 33/45PPWN 03/21 v.4

